



/// RES-Q-JACK[®]

STABILIZATION ELEVATED

2019 PRODUCT CATALOG

2019 RES-Q-JACK® FACTORY

STABILIZATION UNIVERSITY

AT GREEK PEAK MOUNTAIN RESORT

SEPTEMBER 28, 2019

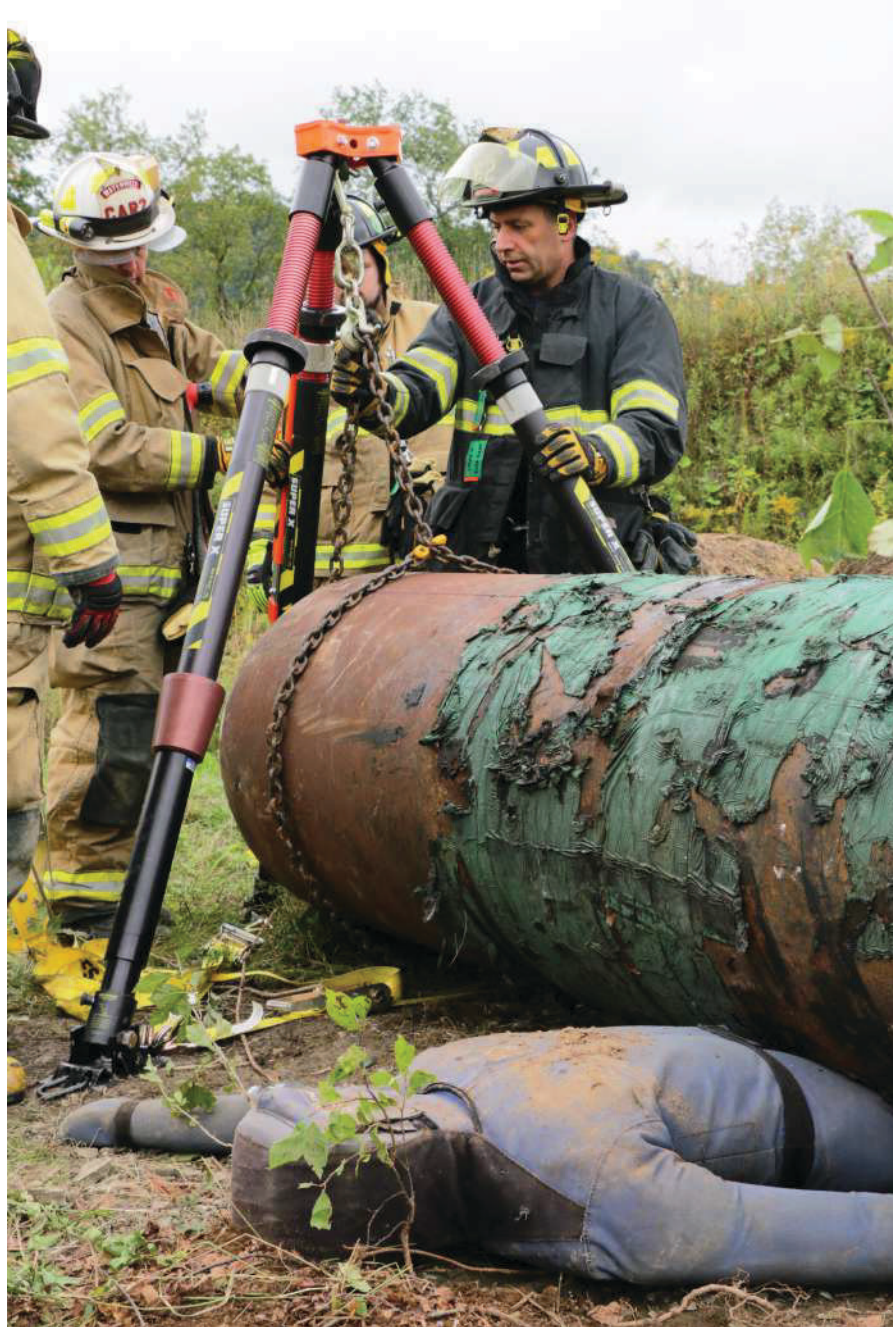

GET THE GEAR

OFFICIAL BRANDED MERCHANDISE



BRANDED T-SHIRT
PRM-TSHT

This is our exclusive branded T-Shirt featuring our logo screen printed across the back and our alternate logo on the left chest. Available in sizes M, L, XL and XXL.



BALL CAP
PRM-RHAT

Newly designed Flexfit hat featuring an embroidered Res-Q-Jack logo on the front. Available in two sizes.



KEYCHAIN LANYARD
PRM-LNYD

Keep track of your keys with this 5/8" thick branded lanyard.

LEARN THE LATEST RES-Q-JACK VEHICLE STABILIZATION & LIFTING TECHNIQUES

1-800-466-9626



f RES-Q-JACK.COM

PATENTED TECHNOLOGY PATENTED TRAINING

Constant research and development of our products and techniques has kept us at the top of the market. Not only do we have unique rescue struts with patented designs, but our techniques are patented as well, through thorough testing and development. And our products all come with free, on-site training! At Res-Q-Jack, we will work hard to supply you with the best equipment possible, and we will show you the best techniques to apply our products as safely and efficiently as possible.

CONTENTS

STRUTS, KITS & JACKS:

Super X-Struts & Kits	5-8
Tech Rescue	9-10
Trench Shore System	11-12
NEW Apex X-Struts & Kits	13-16
Auto X-Struts & Kits	17-20
Aluminum X-Struts & Kits	21-24
Steel X-Struts & Kits	25-28
GreenLite Struts & Kits	29-32
RJ3/Spacesaver Struts & Kits	33-36

ACCESSORIES:

Pin-Free End Fittings	37-38
End Fittings	39-40
Plates & Pins	41-42
Straps & Chains	43-44
Accessory Packages	45
Res-Q-Saw	46



RES-Q-JACK®

OUR TOOLS SAVE LIVES



VERSATILITY. Our tools can be used in a wide range of applications, from simple stabilization to active rescue and extrication of a pinned victim. Most commonly, our struts are used in vehicle, farm, storm, trench, aircraft, confined space, and other rescue environments – but our customers continue to use our products in even more versatile ways.

TRAINING. Our products come with free, hands-on, in-service training. We want you to be comfortable and successful using our tools, and we take no shortcuts in order to ensure that you are properly trained and can use all of our products correctly. Understanding our pioneering stabilization techniques and methods will help your success in the field, and these lessons are integrated into our training program, at your facility.

Since the inception of Res-Q-Jack, we've met the ever-increasing demand for the best in vehicle rescue equipment through innovation, versatility, and training as well as our dedication to listening to our customers and the rescue community at large for new and interesting ideas.

To this end, it is not just our innovative products and training programs that speak volumes as to our role as an aggressive industry leader. Nothing speaks as great as the incredible feedback we get from our customers with appreciation for the dependability of our equipment.

Please contact us if you have any questions or would like a demonstration of our equipment and techniques. And don't miss out on our latest innovations! Visit our web site at www.res-q-jack.com.

All the best,

John H. Meier, President, Res-Q-Jack, Inc.

These words are explicitly stated on an 8-foot sign at our facility because they are the underlying concern of all that we do, from innovation, research, and development to manufacturing, shipping, training, and customer service.

Res-Q-Jack products originated with Cris Pasto in 1992, when he joined his Fire Department and discovered that his BoWrench and other inventions from Cepco Tool could be adapted to stabilization and fire rescue. Pasto then developed several variations of the stabilizing jack stand, and when I acquired the company in 2004, these products grew into what we know today as Res-Q-Jack.

Since its conception, Res-Q-Jack continues to take the lead in vehicle stabilization and extrication tools. Our high performance lifting and rescue struts stand out from the rest because of our unique combination of innovation, versatility, and in-depth training.

INNOVATION. Our engineers are constantly researching and developing, and our many patents are evidence of this consistent innovation. Our patents detail the lightest and strongest lifting struts available for patient access and entrapment; multifunction strut heads for rapid engagement; chains, straps, and stakes for safe restraint; and custom strut materials to fit each individual client's needs.



TECHNICAL SPECS

- 2:1 SAFETY FACTOR**
In-house & 3rd party tested.
- SHORING WORKING LOAD: 19,300 LBS./8,754 KG.**
Hollow inner, fully extended with centered load.
- LIFTING WORKING LOAD: 6,000 LBS./2,721 KG.**
With Add-On Jack, fully extended, centered load.
- WEIGHT LONG STRUT: 46 LBS./21 KG.**
WEIGHT SHORT STRUT: 36 LBS./16 KG.



ADD-ON JACK
SPX-JACK
This jack is made specifically for the Super X-Strut® with a 6,000lbs./2721kg. lifting capacity and a 2:1 safety factor.
Weight: 23lbs./11kg.



SHORT STRUT
SPX-EX41
The short Super X is designed for lower-lift engagements and increased storage options. Comes standard with our Swivel CRG, Small Extrinsic Base Plate, and one Ratchet Strap with Wire Hooks. See extensions on page 39.
Height Extended: 69"/175cm.
Height Collapsed: 51.5"/131cm.



LONG STRUT
SPX-EX56
The standard-length Super X is designed for heavy vehicle and structural rescue. Comes standard with our Swivel CRG, Small Extrinsic Base Plate, and one Ratchet Strap with Wire Hooks.
Height Extended: 100"/255cm.
Height Collapsed: 67.5"/172cm.

SUPER X

X-STRUT® SERIES LIFTING STRUTS

Featuring threaded collars in place of our standard pins, the Super X-Strut® is our most intuitive and fastest-deploying strut. The Super X is not only effective for vehicle stabilization, lifting and extrication. It's also rugged enough for structural collapse, trench, and mine rescue (see our Technical Kits & SPX Trench Shoring systems). The Super X comes standard with a hollow inner tube (red) for a lighter-weight strut, but it may also be purchased with a solid inner tube (black) for a higher working load. With the highest working load of all our struts, the Super X is ideal for heavy rescue, but can also quickly stabilize and lift a small vehicle.

PIN-FREE DESIGN: The Super X-Strut® threaded tube design eliminates the need for pins, making set-up faster than ever. The threaded tube allows for infinitesimal height adjustment when stabilizing or lifting and lowering loads.

QUICK RELEASE HEADS: Change end fittings in an instant with the pull of a single retaining pin. Comes standard with our 360° swiveling head for precise placement on any purchase point.

X-STRUT LIFTING POWER: Transforms from a shoring strut to a lifting strut in seconds with our removable mechanical Add-On Jack, (pictured right) giving you 6,000lbs. of lifting capacity with 12 inches of resettable travel when you need it.

COMPATIBLE HEADS: Super X-Strut® head fittings are compatible with our Apex X-Strut® and Auto X-Strut® fittings as well as competitor head fittings.

AVAILABLE AIR FITTINGS: Call us to ask about having the Super X-Strut® milled with our air fitting for use with pneumatic systems.

SUPER X

COMPLETE KITS

1. CHOOSE YOUR KIT

We've designed our kits through years of experience and feedback to give you options to fit your needs and your budget.

2. CHOOSE YOUR STRUTS

Choose any combination of short or long strut. When choosing sizes, we recommend an equal number of short and long struts when possible.

3. GET YOUR FREE TRAINING*

All of our kits come with intensive in-service training at your facility, at no cost to you! Your authorized dealer will provide you and your crew basic training on your new tools until you are comfortable using them.

*Valid within the continental US only. Dealer may add a travel charge for instances of excessive travel.



2-POINT STANDARD KIT SPX-2KIT

This kit gives you the ability to perform the four basic techniques found in our Quick Reference Guide, including: Wheel-Resting Side Lift, Wheel-Resting Rear Lift, Side-Resting Front Lift, and Roof-Resting Rear Lift.

Kit Contents:

- (2) Super X-Struts (short or long)
- (2) Super X-Strut Add-On Jacks
- (1) Ratchet Straps w/ Wire Hooks
- (2) Ratchet Straps w/ Snaps
- (2) Clusters
- (2) 4' Chains w/ 8" J, Grabs, Mini-J & T-Hook
- (1) Grade 80 Chain w/ Grab Hooks



4-POINT DELUXE KIT SPX-4PTX

This kit gives you the ability to stabilize two cars and lift one of them. With enough accessories to manage and control all directions of movement, this kit is the best all-around package.

Kit Contents:

- (4) Super X-Struts (short or long)
- (2) Super X-Strut Add-On Jacks
- (2) Ratchet Straps w/ Wire Hooks
- (2) Ratchet Straps w/ Chains
- (3) Ratchet Straps w/ Snaps
- (4) Clusters
- (4) 4' Chains w/ 8" J, Grabs, Mini-J & T-Hook
- (1) Grade 80 Chain w/ Grab Hooks
- (2) Wood/Plastic Hybrid Wedges
- (2) 20" long 1" Stakes w/ Heads
- (2) 4' long 1" Pickets w/ Collars



TEXAS 3-POINT KIT SPX-TX3P

This kit allows for stabilization and lifting of one car. Because the kit comes with a variety of accessories, it is also suitable for stabilization in complicated or multi-vehicle scenarios.

KitContents:

- (3) Super X-Struts (short or long)
- (2) Super X-Strut Add-On Jacks
- (1) Ratchet Straps w/ Wire Hooks
- (2) Ratchet Straps w/ Chains
- (3) Ratchet Straps w/ Snaps
- (4) Clusters
- (2) 4' Chains w/ 8" J, Grabs, Mini-J & T-Hook
- (1) Grade 80 Chain w/ Grab Hooks
- (2) Wood/Plastic Hybrid Wedges
- (1) 4' long 1" Picket w/ Collars



2-CAR DELUXE KIT SPX-2CRX

This kit is capable of stabilizing and lifting two cars in almost any situation, and can handle up to three cars in a more simple application. Accessories allow for many different applications and make stabilization in complex scenarios faster and easier.

Kit Contents:

- (6) Super X-Struts (short or long)
- (3) Super X-Strut Add-On Jacks
- (4) Ratchet Straps w/ Wire Hooks
- (2) Ratchet Straps w/ Chains
- (3) Ratchet Straps w/ Snaps
- (4) Clusters
- (4) 4' Chains w/ 8" J, Grabs, Mini-J & T-Hook
- (1) Grade 80 Chain w/ Grab Hooks
- (4) Wood/Plastic Hybrid Wedges
- (4) Load Spread Pads
- (4) 20" long 1" Stakes w/ Heads
- (4) 4' long 1" Pickets w/ Collars





SUPER TECHNICAL RESCUE KITS

Our technical rescue kits feature our heavy duty Super X-Strut®, along with a wide variety of end fittings that have applications in trench, mine, collapse and vehicle rescue environments. These versatile kits are suited for whatever scenario you may encounter.

12-POINT TECH RESCUE KIT SPX-12PT

- Includes:**
- (6) Long Super X-Strut Bodies
 - (6) Short Super X-Strut Bodies
 - (8) Add-On Jacks
 - (3) 12"/31cm. Extensions
 - (3) 24"/62cm. Extensions
 - (3) 36"/92cm. Extensions
 - (8) Swivel CRG Head Fittings
 - (12) Flat Plate End Fittings
 - (12) Trench Plate End Fittings
 - (8) Large Base Plates



6-POINT TECH RESCUE KIT SPX-6PTK

- Includes:**
- (3) Long Super X-Strut Bodies
 - (3) Short Super X-Strut Bodies
 - (4) Add-On Jacks
 - (2) 12"/31cm. Extensions
 - (2) 24"/62cm. Extensions
 - (1) 36"/92cm. Extensions
 - (4) Swivel CRG Head Fittings
 - (6) Flat Plate End Fittings
 - (6) Trench Plate End Fittings
 - (4) Large Base Plates



3-POINT TECH RESCUE KIT SPX-3PTK

- Includes:**
- (1) Long Super X-Strut Bodies
 - (2) Short Super X-Strut Bodies
 - (2) Add-On Jacks
 - (1) 12"/31cm. Extensions
 - (1) 24"/62cm. Extensions
 - (1) 36"/92cm. Extensions
 - (2) Swivel CRG Head Fittings
 - (3) Flat Plate End Fittings
 - (3) Trench Plate End Fittings
 - (2) Large Base Plates

SPX

TRENCH RESCUE SYSTEMS

The Super X Trench Shoring System excels in any trench rescue scenario. Machined from high grade aluminum and featuring the same functionality as our Super X-Strut® line, the Trench Shoring System will meet all your trench shoring needs. These struts are available in three sizes to accommodate a variety of situations, and each is compatible with our Super X-Strut® components, as well as competitor components.



12-POINT TRENCH SHORE KIT

SPX-12TRK

Includes:

- (6) 38"/96.5 cm. Trench Shores
- (4) 28"/71 cm. Trench Shores
- (2) 18"/46 cm. Trench Shores
- (2) 36"/92 cm. Extensions
- (2) 24"/61 cm. Extensions
- (2) 12"/31 cm. Extensions
- (18) Swivel Plates
- (6) Flat Plates
- (4) Air Inflator Kits (not pictured)

TECHNICAL SPECS

2:1 SAFETY FACTOR
In-house & 3rd party tested

SHORING WLL:
At various lengths

26"	38,000 LBS.
50"	30,600 LBS.
74"	25,150 LBS.
94"	14,180 LBS.
112"	10,400 LBS.

8-POINT TRENCH SHORE KIT

SPX-8TRK

Includes:

- (4) 38"/96.5 cm. Trench Shores
- (2) 28"/71 cm. Trench Shores
- (2) 18"/46 cm. Trench Shores
- (2) 36"/92 cm. Extensions
- (2) 24"/61 cm. Extensions
- (2) 12"/31 cm. Extensions
- (12) Swivel Plates
- (4) Flat Plates
- (3) Air Inflator Kits (not pictured)



6-POINT TRENCH SHORE KIT

SPX-6TRK

Includes:

- (2) 38"/96.5 cm. Trench Shores
- (2) 28"/71 cm. Trench Shores
- (2) 18"/46 cm. Trench Shores
- (1) 36"/92 cm. Extensions
- (1) 24"/61 cm. Extensions
- (1) 12"/31 cm. Extensions
- (8) Swivel Plates
- (4) Flat Plates
- (1) Air Inflator Kits (not pictured)



* Trench shore lengths represent fully assembled product with two swivel trench plates.



TECHNICAL SPECS

- 2:1 SAFETY FACTOR**
In-house & 3rd party tested.
- SHORING WORKING LOAD:** 12,500 LBS./5,669 KG. (SHORT STRUT)
Fully extended with centered load 7,750 LBS./3,515 KG. (LONG STRUT)
without extensions.
- LIFTING WORKING LOAD:** 6,000 LBS./2,721 KG.
With Add-On Jack, fully extended, centered load.
- WEIGHT LONG STRUT:** 41 LBS./19 KG.
WEIGHT SHORT STRUT: 33 LBS./15 KG.



ADD-ON JACK
APX-JACK
This jack is made specifically for the new Apex X-Strut® with a 6,000lbs./2,721kg. lifting capacity and a 2:1 safety factor.
Weight: 20lbs./9kg.



SHORT STRUT
APX-STRT-S
The short Apex is a more compact version of the long strut for more versatility in low-lift situations and storage. Comes standard with Swivel CRG end fitting and Ratchet Strap with Wire Hooks (not built-in on short strut).
Height Extended: 62.75"/160cm.
Height Collapsed: 45.5"/115cm.



LONG STRUT
APX-STRT-L
The standard-length Apex is a fast, all-in-one strut for most rescue scenarios. Comes standard with our Swivel CRG end fitting and built-in Ratchet Strap with Wire Hooks.
Height Extended: 91.5"/233cm.
Height Collapsed: 58.75"/150cm.

APEX

X-STRUT® SERIES LIFTING STRUTS

The new Apex X-Strut® takes the popular design of our Auto X-Strut® and beefs it up for even more capability. This well rounded strut features the combination of a square aluminum outer tube, allowing for a ratchet on the standard size strut and an internal positive stop to eliminate the risk of over extension. Accepts the Super X 12" extension on both the short and standard size strut.

PIN-FREE/TWIST-FREE: Threaded inner tubing allows for fast and smooth adjustment without pins, making setup and chasing a breeze. The threaded tube allows for infinitesimal height adjustment when stabilizing or lifting and lowering loads. The unique design allows for a positive stop, keeping the inner tube from rotating under lighter loads, and eliminating the risk of overextension.

QUICK RELEASE HEADS: Change end fittings in an instant with the pull of a single retaining pin. Comes standard with our 360° swiveling head for precise placement on any purchase point.

X-STRUT LIFTING POWER: Transforms from a shoring strut to a lifting strut in seconds with our removable mechanical Add-On Jack, (pictured right) giving you 6,000lbs. (2:1) of lifting capacity with 12 inches of resettable travel when you need it.

COMPATIBLE HEADS: Apex X-Strut® head fittings are compatible with our Super X-Strut® and Auto X-Strut® fittings, as well as competitor head fittings.

APEX

COMPLETE KITS

1. CHOOSE YOUR KIT

We've designed our kits through years of experience and feedback to give you options to fit your needs and your budget.

2. CHOOSE YOUR STRUTS

Choose any combination of short or long strut. When choosing sizes, we recommend an equal number of short and long struts when possible.

3. GET YOUR FREE TRAINING*

All of our kits come with intensive in-service training at your facility, at no cost to you! Your authorized dealer will provide you and your crew basic training on your new tools until you are comfortable using them.

*Valid within the continental US only. Dealer may add a travel charge for instances of excessive travel.



2-POINT STANDARD KIT APX-2KIT

This kit gives you the ability to perform the four basic techniques found in our Quick Reference Guide, including: Wheel-Resting Side Lift, Wheel-Resting Rear Lift, Side-Resting Front Lift, and Roof-Resting Rear Lift.

Kit Contents:

- (2) Apex X-Struts (short or long)
- (2) Apex X-Strut Add-On Jacks

- (1) Ratchet Straps w/ Wire Hooks
- (2) Ratchet Straps w/ Snaps
- (2) Clusters
- (2) 4' Chains w/ 8" J, Grabs, Mini-J & T-Hook
- (1) Grade 80 Chain w/ Grab Hooks



4-POINT DELUXE KIT APX-4PTX

This kit gives you the ability to stabilize two cars and lift one of them. With enough accessories to manage and control all directions of movement, this kit is the best all-around package.

Kit Contents:

- (4) Apex X-Struts (short or long)
- (2) Apex X-Strut Add-On Jacks

- (2) Ratchet Straps w/ Wire Hooks
- (2) Ratchet Straps w/ Chains
- (3) Ratchet Straps w/ Snaps
- (4) Clusters
- (4) 4' Chains w/ 8" J, Grabs, Mini-J & T-Hook
- (1) Grade 80 Chain w/ Grab Hooks
- (2) Wood/Plastic Hybrid Wedges
- (2) 20" long 1" Stakes w/ Heads
- (2) 4' long 1" Pickets w/ Collars



TEXAS 3-POINT KIT APX-TX3P

This kit allows for stabilization and lifting of one car. Because the kit comes with a variety of accessories, it is also suitable for stabilization in complicated or multi-vehicle scenarios.

KitContents:

- (3) Apex X-Struts (short or long)
- (2) Apex X-Strut Add-On Jacks

- (1) Ratchet Straps w/ Wire Hooks
- (2) Ratchet Straps w/ Chains
- (3) Ratchet Straps w/ Snaps
- (2) Clusters
- (2) 4' Chains w/ 8" J, Grabs, Mini-J & T-Hook
- (1) Grade 80 Chain w/ Grab Hooks
- (2) Wood/Plastic Hybrid Wedges
- (1) 4' long 1" Picket w/ Collars



2-CAR DELUXE KIT APX-2CRX

This kit is capable of stabilizing and lifting two cars in almost any situation, and can handle up to three cars in a more simple application. Accessories allow for many different applications and make stabilization in complex scenarios faster and easier.

Kit Contents:

- (6) Apex X-Struts (short or long)
- (3) Apex X-Strut Add-On Jacks

- (4) Ratchet Straps w/ Wire Hooks
- (2) Ratchet Straps w/ Chains
- (3) Ratchet Straps w/ Snaps
- (4) Clusters
- (4) 4' Chains w/ 8" J, Grabs, Mini-J & T-Hook
- (1) Grade 80 Chain w/ Grab Hooks
- (4) Wood/Plastic Hybrid Wedges
- (4) Load Spread Pads
- (4) 20" long 1" Stakes w/ Heads
- (4) 4' long 1" Pickets w/ Collars





TECHNICAL SPECS

- 2:1 SAFETY FACTOR**
In-house & 3rd party tested.
- SHORING WORKING LOAD:** 3,250 LBS./1,474 KG.
Fully extended with centered load.
- LIFTING WORKING LOAD:** 2,500 LBS./1,133 KG.
With Add-On Jack, fully extended, centered load.
- WEIGHT LONG STRUT:** 33 LBS./15 KG.
WEIGHT SHORT STRUT: 30 LBS./14 KG.



ADD-ON JACK
ATX-JACK
This jack is made specifically for the Auto X-Strut® with a 2,500lbs./1,133kg. lifting capacity and a 2:1 safety factor.
Weight: 15lbs./7kg.

SHORT STRUT
ATX-STRT-S
The short Auto X is a compact, easily portable, easily storable, all-in-one strut. The short Auto X accepts our Super X 12" extension for more length (pg 38). Comes standard with our Swivel CRG end fitting and built-in Ratchet Strap with Wire Hooks.
Height Extended: 67"/171cm.
Height Collapsed: 44"/112cm.

LONG STRUT
ATX-STRT-L
The standard-length Auto X is a light-weight, easily portable, all-in-one strut for light-duty rescue scenarios. Comes standard with our Swivel CRG end fitting and built-in Ratchet Strap with Wire Hooks. (Extensions are not permitted on standard size strut).
Height Extended: 88"/224cm.
Height Collapsed: 54.5"/139cm.

AUTO X

X-STRUT® SERIES LIFTING STRUTS

The Auto X-Strut® First Responder Strut puts the speed of pin-free operation in a compact package for the most intuitive, fastest-deploying vehicle stabilization & lifting strut on the market. This light-weight, ultra-portable strut features a milled aluminum inner tube, allowing for fast and smooth adjustment without the need for pins. The unique combination of a square aluminum outer tube allows for a built-in ratchet strap which doubles as a convenient carry handle, while the internal positive stop eliminates the risk of overextension.

PIN-FREE/TWIST-FREE: Threaded inner tubing allows for fast and smooth adjustment without pins, making setup and chasing a breeze. The threaded tube allows for infinitesimal height adjustment when stabilizing or lifting and lowering loads. The unique design allows for a positive stop, keeping the inner tube from rotating under lighter loads, and eliminating the risk of overextension.

QUICK RELEASE HEADS: Change end fittings in an instant with the pull of a single retaining pin. Comes standard with our 360° swiveling head for precise placement on any purchase point.

X-STRUT LIFTING POWER: Transforms from a shoring strut to a lifting strut in seconds with our removable mechanical Add-On Jack, (pictured right) giving you 2,500 lbs. of lifting capacity with 12 inches of resettable travel when you need it.

COMPATIBLE HEADS: Auto X-Strut® head fittings are compatible with our Apex X-Strut® and Super X-Strut® fittings, as well as competitor head fittings.

AUTO X

COMPLETE KITS

1. CHOOSE YOUR KIT

We've designed our kits through years of experience and feedback to give you options to fit your needs and your budget.

2. CHOOSE YOUR STRUTS

Choose any combination of short or long strut. When choosing sizes, we recommend an equal number of short and long struts when possible.

3. GET YOUR FREE TRAINING*

All of our kits come with intensive in-service training at your facility, at no cost to you!* Your authorized dealer will provide you and your crew basic training on your new tools until you are comfortable using them.

*Valid within the continental US only. Dealer may add a travel charge for instances of excessive travel.



2-POINT STANDARD KIT
ATX-2KIT

This kit gives you the ability to perform the four basic techniques found in our Quick Reference Guide, including: Wheel-Resting Side Lift, Wheel-Resting Rear Lift, Side-Resting Front Lift, and Roof-Resting Rear Lift.

Kit Contents:
(2) Auto X-Struts (short or long)
(2) Auto X-Strut Add-On Jacks

(1) Ratchet Straps w/ Wire Hooks
(2) Ratchet Straps w/ Snaps
(2) Clusters
(2) 4' Chains w/ 8" J, Grabs, Mini-J & T-Hook
(1) Grade 80 Chain w/ Grab Hooks



4-POINT DELUXE KIT
ATX-4PTX

This kit gives you the ability to stabilize two cars and lift one of them. With enough accessories to manage and control all directions of movement, this kit is the best all-around package.

Kit Contents:
(4) Auto X-Struts (short or long)
(2) Auto X-Strut Add-On Jacks
(2) Ratchet Straps w/ Wire Hooks
(2) Ratchet Straps w/ Chains
(3) Ratchet Straps w/ Snaps
(4) Clusters
(4) 4' Chains w/ 8" J, Grabs, Mini-J & T-Hook
(1) Grade 80 Chain w/ Grab Hooks
(2) Wood/Plastic Hybrid Wedges
(2) 20" long 1" Stakes w/ Heads
(2) 4' long 1" Pickets w/ Collars



TEXAS 3-POINT KIT
ATX-TX3P

This kit allows for stabilization and lifting of one car. Because the kit comes with a variety of accessories, it is also suitable for stabilization in complicated or multi-vehicle scenarios.

KitContents:
(3) Auto X-Struts (short or long)
(2) Auto X-Strut Add-On Jacks
(1) Ratchet Straps w/ Wire Hooks
(2) Ratchet Straps w/ Chains
(3) Ratchet Straps w/ Snaps
(2) Clusters
(2) 4' Chains w/ 8" J, Grabs, Mini-J & T-Hook
(1) Grade 80 Chain w/ Grab Hooks
(2) Wood/Plastic Hybrid Wedges
(1) 4' long 1" Picket w/ Collars



2-CAR DELUXE KIT
ATX-2CRX

This kit is capable of stabilizing and lifting two cars in almost any situation, and can handle up to three cars in a more simple application. Accessories allow for many different applications and make stabilization in complex scenarios faster and easier.

Kit Contents:
(6) Auto X-Struts (short or long)
(3) Auto X-Strut Add-On Jacks
(4) Ratchet Straps w/ Wire Hooks
(2) Ratchet Straps w/ Chains
(3) Ratchet Straps w/ Snaps
(4) Clusters
(4) 4' Chains w/ 8" J, Grabs, Mini-J & T-Hook
(1) Grade 80 Chain w/ Grab Hooks
(4) Wood/Plastic Hybrid Wedges
(4) Load Spread Pads
(4) 20" long 1" Stakes w/ Heads
(4) 4' long 1" Pickets w/ Collars

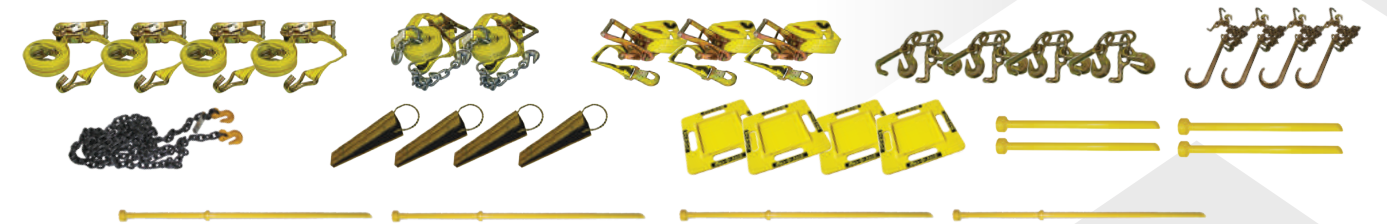



TECHNICAL SPECS

- 2:1 SAFETY FACTOR**
In-house & 3rd party tested.
- SHORING WORKING LOAD: 9,700 LBS./ 4,399 KG.**
Fully extended with centered load.
- LIFTING WORKING LOAD: 6,000 LBS./ 2,721 KG.**
With Add-On Jack, fully extended, centered load.
- WEIGHT LONG STRUT: 42 LBS./ 19 KG.**
WEIGHT PHOENIX STRUT: 37 LBS./ 17 KG.
WEIGHT SHORT STRUT: 30 LBS./ 14 KG.



ADD-ON JACK
ALX-JACK
This jack is made specifically for the Aluminum X-Strut® with a 6,000lbs./2,721kg. lifting capacity and a 2:1 safety factor.
Weight: 25lbs./11kg.



SHORT STRUT
SAX-STRT
The short Aluminum X is designed for lower-lift engagements and increased storage options. Comes standard with our Swivel CRG, and one Ratchet Strap with Wire Hooks. *Ratchet Strap NOT built-in on short strut.*
Height Extended: 66.5"/169cm.
Height Collapsed: 40"/102cm.



LONG STRUT | PHOENIX STRUT
ALX-STRT | ALX-STRT-PH (Phoenix)
The standard-length Aluminum X is designed for typical heavy-duty rescue scenarios. Comes standard with our Swivel CRG and built-in Ratchet Strap with Wire Hooks. The Phoenix Aluminum X (not pictured) boasts all the same features as the full-sized model, but at a slightly smaller size for easy storage.
Long Strut –
Height Extended: 98"/250cm.
Height Collapsed: 56"/143cm.
Phoenix –
Height Extended: 86.5"/220cm.
Height Collapsed: 51"/128cm.

ALUMINUM X

X-STRUT® SERIES LIFTING STRUTS

The Aluminum X is a premium lifting strut built from 6061-T6 aluminum and boasting a 10,000lb. working load limit, without adding significant weight. With the X-Strut® Series Add-On Jack technology delivering 6,000lbs. of lifting power, this strut is heavy duty in a manageable package, allowing for easy deployment and the ability to focus on a potential victim inside the vehicle. Our lightweight, but high performance Aluminum X is great for departments who see heavier vehicle accidents or who want the added security of a heavy-duty strut.

OVERSIZE CONE PINS: The Aluminum X-Strut® operates with our custom-manufactured oversize cone pins. The special flared-design automatically aligns with the jack for faster setup. The unique shape also makes these pins easier to grip and harder to lose.

X-STRUT® LIFTING POWER: The Aluminum X-Strut® transforms from a shoring strut to a lifting strut in seconds with our removable mechanical Add-On Jack, (pictured right) giving you 6,000 lbs. of lifting capacity with 12 inches of resettable travel when you need it.

ON-BOARD RATCHET: The Aluminum X-Strut® and Phoenix Aluminum X-Strut® each include a ratchet strap with wire hooks mounted on the side of the strut chassis, keeping your strap right where you want it for faster response.

BASE-MOUNTED D-RINGS: Pivoting rings built into the base plate allow for fast attachment of straps, hooks and chains, or double as a picket receiver when anchoring is needed.

ALUMINUM

COMPLETE KITS

1. CHOOSE YOUR KIT

We've designed our kits through years of experience and feedback to give you options to fit your needs and your budget.

2. CHOOSE YOUR STRUTS

Choose any combination of short or long strut. When choosing sizes, we recommend an equal number of short and long struts when possible.

3. GET YOUR FREE TRAINING*

All of our kits come with intensive in-service training at your facility, at no cost to you!* Your authorized dealer will provide you and your crew basic training on your new tools until you are comfortable using them.

*Valid within the continental US only. Dealer may add a travel charge for instances of excessive travel.



2-POINT STANDARD KIT
ALX-2KIT | ALX-PH2P (Phoenix struts)

This kit gives you the ability to perform the four basic techniques found in our Quick Reference Guide, including: Wheel-Resting Side Lift, Wheel-Resting Rear Lift, Side-Resting Front Lift, and Roof-Resting Rear Lift.

- Kit Contents:**
(2) Aluminum X-Struts (short or long)
(2) Aluminum X-Strut Add-On Jacks

- (1) Ratchet Straps w/ Wire Hooks
(2) Ratchet Straps w/ Snaps
(2) Clusters
(2) 4' Chains w/ 8" J, Grabs, Mini-J & T-Hook
(1) Grade 80 Chain w/ Grab Hooks



4-POINT DELUXE KIT
ALX-4PTX

This kit gives you the ability to stabilize two cars and lift one of them. With enough accessories to manage and control all directions of movement, this kit is the best all-around package.

- Kit Contents:**
(4) Aluminum X-Struts (short or long)
(2) Aluminum X-Strut Add-On Jacks

- (2) Ratchet Straps w/ Wire Hooks
(2) Ratchet Straps w/ Chains
(3) Ratchet Straps w/ Snaps
(4) Clusters
(4) 4' Chains w/ 8" J, Grabs, Mini-J & T-Hook
(1) Grade 80 Chain w/ Grab Hooks
(2) Wood/Plastic Hybrid Wedges
(2) 20" long 1" Stakes w/ Heads
(2) 4' long 1" Pickets w/ Collars



TEXAS 3-POINT KIT
ALX-TX3P

This kit allows for stabilization and lifting of one car. Because the kit comes with a variety of accessories, it is also suitable for stabilization in complicated or multi-vehicle scenarios.

- Kit Contents:**
(3) Aluminum X-Struts (short or long)
(3) Aluminum X-Strut Add-On Jacks

- (1) Ratchet Straps w/ Wire Hooks
(2) Ratchet Straps w/ Chains
(3) Ratchet Straps w/ Snaps
(2) Clusters
(2) 4' Chains w/ 8" J, Grabs, Mini-J & T-Hook
(1) Grade 80 Chain w/ Grab Hooks
(2) Wood/Plastic Hybrid Wedges
(1) 4' long 1" Picket w/ Collars



2-CAR DELUXE KIT
ALX-2CRX

This kit is capable of stabilizing and lifting two cars in almost any situation, and can handle up to three cars in a more simple application. Accessories allow for many different applications and make stabilization in complex scenarios faster and easier.

- Kit Contents:**
(6) Aluminum X-Struts (short or long)
(3) Aluminum X-Strut Add-On Jacks

- (4) Ratchet Straps w/ Wire Hooks
(2) Ratchet Straps w/ Chains
(3) Ratchet Straps w/ Snaps
(4) Clusters
(4) 4' Chains w/ 8" J, Grabs, Mini-J & T-Hook
(1) Grade 80 Chain w/ Grab Hooks
(4) Wood/Plastic Hybrid Wedges
(4) Load Spread Pads
(4) 20" long 1" Stakes w/ Heads
(4) 4' long 1" Pickets w/ Collars

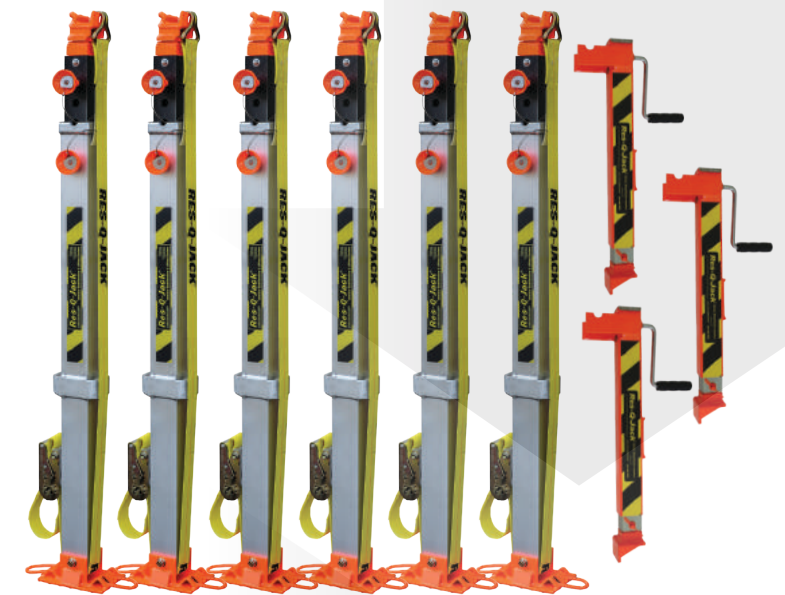



TECHNICAL SPECS

- 2:1** **2:1 SAFETY FACTOR**
In-house & 3rd party tested.
- SHORING WORKING LOAD:** **4,000 LBS./ 1,814 KG.**
Fully extended with centered load.
- LIFTING WORKING LOAD:** **4,000 LBS./ 1,814 KG.**
With Add-On Jack, fully extended, centered load.
- WEIGHT LONG STRUT:** **38 LBS./ 17 KG.**
WEIGHT SHORT STRUT: **27 LBS./ 12 KG.**

STEEL X

X-STRUT® SERIES LIFTING STRUTS

The Steel X-Strut® is the most well-rounded steel stabilization strut on the market. The Steel X-Strut® is a heavy duty and affordable addition to the X-Strut® Series. Filling the gap between the lightweight Green Lite™ and our premium Aluminum X, the Steel X combines the functionality of the X-Strut® Series with enough working load for all of your common rescue situations.

X-STRUT® LIFTING POWER: Transforms from a shoring strut to a lifting strut in seconds with our removable mechanical Add-On Jack, (pictured right) giving you 4,000 lbs. of lifting capacity with 12 inches of resettable travel when you need it.

ERGONOMIC CONE PINS: Our exclusive cone pin design features a flared end, making these pins easy to grip and hard to lose on scene. The flared end also helps automatically line up the available Add-On Jack for fast and easy attachment.

ON-BOARD RATCHET: The Steel X-Strut® includes a ratchet strap with wire hooks mounted on the side of the strut chassis, keeping your strap right where you want it for faster response.

BASE-MOUNTED D-RINGS: Pivoting rings built into the base plate allow for fast attachment of straps, hooks and chains, or double as a picket receiver when anchoring is needed.



ADD-ON JACK
STX-JACK

This jack is made specifically for the Steel X-Strut® with a 4,000lbs./1,814kg. lifting capacity and a 2:1 safety factor.

Weight: 23lbs./10kg.



SHORT STRUT
SSX-STRT

The short Steel X is designed for lower-lift engagements and increased storage options. Comes standard with our Swivel CRG, and one Ratchet Strap with Wire Hooks. *Ratchet Strap NOT built-in on short strut.*

Height Extended: 58.5"/148cm.
Height Collapsed: 40.5"/103cm.



LONG STRUT
STX-STRT

The standard-length Steel X is designed for typical rescue scenarios involving most common vehicles. Comes standard with our Swivel CRG and built-in Ratchet Strap with Wire Hooks.

Height Extended: 81.5"/207cm.
Height Collapsed: 53.5"/136cm.

STEEL X-STRUT

COMPLETE KITS

1. CHOOSE YOUR KIT

We've designed our kits through years of experience and feedback to give you options to fit your needs and your budget.

2. CHOOSE YOUR STRUTS

Choose any combination of short or long strut. When choosing sizes, we recommend an equal number of short and long struts when possible.

3. GET YOUR FREE TRAINING*

All of our kits come with intensive in-service training at your facility, at no cost to you!* Your authorized dealer will provide you and your crew basic training on your new tools until you are comfortable using them.

*Valid within the continental US only. Dealer may add a travel charge for instances of excessive travel.



2-POINT STANDARD KIT
STX-2KIT

This kit gives you the ability to perform the four basic techniques found in our Quick Reference Guide, including: Wheel-Resting Side Lift, Wheel-Resting Rear Lift, Side-Resting Front Lift, and Roof-Resting Rear Lift.

- Kit Contents:**
 (2) Steel X-Struts (*short or long*)
 (2) Steel X-Strut Add-On Jacks

- (1) Ratchet Straps w/ Wire Hooks
 (2) Ratchet Straps w/ Snaps
 (2) Clusters
 (2) 4' Chains w/ 8" J, Grabs, Mini-J & T-Hook
 (1) Grade 80 Chain w/ Grab Hooks



4-POINT DELUXE KIT
STX-4PTX

This kit gives you the ability to stabilize two cars and lift one of them. With enough accessories to manage and control all directions of movement, this kit is the best all-around package.

- Kit Contents:**
 (4) Steel X-Struts (*short or long*)
 (2) Steel X-Strut Add-On Jacks
 (2) Ratchet Straps w/ Wire Hooks
 (2) Ratchet Straps w/ Chains
 (3) Ratchet Straps w/ Snaps
 (4) Clusters
 (4) 4' Chains w/ 8" J, Grabs, Mini-J & T-Hook
 (1) Grade 80 Chain w/ Grab Hooks
 (2) Wood/Plastic Hybrid Wedges
 (2) 20" long 1" Stakes w/ Heads
 (2) 4' long 1" Pickets w/ Collars



TEXAS 3-POINT KIT
STX-TX3P

This kit allows for stabilization and lifting of one car. Because the kit comes with a variety of accessories, it is also suitable for stabilization in complicated or multi-vehicle scenarios.

- Kit Contents:**
 (3) Steel X-Struts (*short or long*)
 (2) Steel X-Strut Add-On Jacks
 (1) Ratchet Straps w/ Wire Hooks
 (2) Ratchet Straps w/ Chains
 (3) Ratchet Straps w/ Snaps
 (2) Clusters
 (2) 4' Chains w/ 8" J, Grabs, Mini-J & T-Hook
 (1) Grade 80 Chain w/ Grab Hooks
 (2) Wood/Plastic Hybrid Wedges
 (1) 4' long 1" Picket w/ Collars



2-CAR DELUXE KIT
STX-2CRX

This kit is capable of stabilizing and lifting two cars in almost any situation, and can handle up to three cars in a more simple application. Accessories allow for many different applications and make stabilization in complex scenarios faster and easier.

- Kit Contents:**
 (6) Steel X-Struts (*short or long*)
 (3) Steel X-Strut Add-On Jacks
 (4) Ratchet Straps w/ Wire Hooks
 (2) Ratchet Straps w/ Chains
 (3) Ratchet Straps w/ Snaps
 (4) Clusters
 (4) 4' Chains w/ 8" J, Grabs, Mini-J & T-Hook
 (1) Grade 80 Chain w/ Grab Hooks
 (4) Wood/Plastic Hybrid Wedges
 (4) Load Spread Pads
 (4) 20" long 1" Stakes w/ Heads
 (4) 4' long 1" Pickets w/ Collars

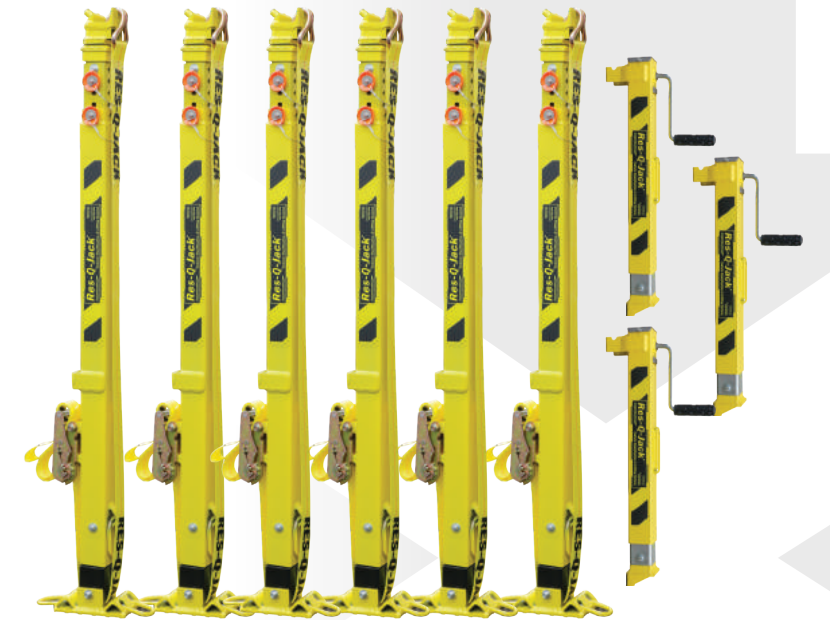



TECHNICAL SPECS

- 2:1 SAFETY FACTOR**
In-house & 3rd party tested.
- SHORING WORKING LOAD: 2,500 LBS./ 1,133 KG.**
Fully extended with centered load.
- LIFTING WORKING LOAD: 2,500 LBS./ 1,133 KG.**
With Add-On Jack, fully extended, centered load.
- WEIGHT LONG STRUT: 29 LBS./ 13 KG.**
WEIGHT SHORT STRUT: 22 LBS./ 10 KG.



ADD-ON JACK
GLX-JACK
This jack is made specifically for the GreenLite™ with a 2,500lbs./1,133kg. lifting capacity and a 2:1 safety factor.
Jack Weight: 12lbs./5kg.

SHORT STRUT
SGL-STRT
The short GreenLite is designed for lower-lift engagements and increased storage options. Comes standard with our Swivel CRG, and one Ratchet Strap with Wire Hooks. *Ratchet Strap NOT built-in on short strut.*
Height Extended: 62"/158cm.
Height Collapsed: 42"/107cm.

LONG STRUT
GLX-STRT
The standard-length GreenLite is designed for typical rescue scenarios involving smaller vehicles. Comes standard with our Swivel CRG and built-in Ratchet Strap with Wire Hooks.
Height Extended: 85.5"/217cm.
Height Collapsed: 54.5"/138cm.

GREENLITE™

X-STRUT® SERIES LIFTING STRUTS

You don't need to sacrifice quality or effectiveness to come in at your budget. The GreenLite™ X-Strut® boasts the same features as our bigger struts, but is scaled down for use with lighter-duty vehicles. When combined with the Add-On Jack, our GreenLite™ is hands-down, the MOST CAPABLE strut you can get in this price range. This light-duty strut packs all the features of the X-Strut® Series, but measures in at a fraction of the weight. With a 2,500 lb. working load limit, the Green Lite™ is perfect for departments that see many compact car accidents. Using the Green Lite™ Add-On Jack, you'll also get an additional 2,500lbs. of lift! The Green Lite™ is an affordable and lightweight way to outfit your rescue.

X-STRUT® LIFTING POWER: Transforms from a shoring strut to a lifting strut in seconds with our removable mechanical Add-On Jack, (pictured right) giving you 2,500 lbs. (2:1) of lifting capacity with 12 inches of resettable travel when you need it.

ERGONOMIC CONE PINS: Our exclusive cone pin design features a flared end, making these pins easy to grip and hard to lose on scene. The flared end also helps automatically line up the available Add-On Jack for fast and easy attachment.

ON-BOARD RATCHET: The standard size GreenLite™ X-Strut® includes a ratchet strap with wire hooks mounted on the side of the strut chassis, keeping your strap right where you want it for faster response.

BASE-MOUNTED D-RINGS: Pivoting rings built into the base plate allow for fast attachment of straps, hooks and chains, or double as a picket receiver when anchoring is needed.

GREENLITE™

COMPLETE KITS

1. CHOOSE YOUR KIT

We've designed our kits through years of experience and feedback to give you options to fit your needs and your budget.

2. CHOOSE YOUR STRUTS

Choose any combination of short or long strut. When choosing sizes, we recommend an equal number of short and long struts when possible.

3. GET YOUR FREE TRAINING*

All of our kits come with intensive in-service training at your facility, at no cost to you! Your authorized dealer will provide you and your crew basic training on your new tools until you are comfortable using them.

*Valid within the continental US only. Dealer may add a travel charge for instances of excessive travel.



2-POINT STANDARD KIT GLX-2KIT

This kit gives you the ability to perform the four basic techniques found in our Quick Reference Guide, including: Wheel-Resting Side Lift, Wheel-Resting Rear Lift, Side-Resting Front Lift, and Roof-Resting Rear Lift.

Kit Contents:

- (2) GreenLite X-Struts (short or long)
- (2) GreenLite X-Strut Add-On Jacks

- (1) Ratchet Straps w/ Wire Hooks
- (2) Ratchet Straps w/ Snaps
- (2) Clusters
- (2) 4' Chains w/ 8" J, Grabs, Mini-J & T-Hook
- (1) Grade 80 Chain w/ Grab Hooks



4-POINT DELUXE KIT GLX-4PTX

This kit gives you the ability to stabilize two cars and lift one of them. With enough accessories to manage and control all directions of movement, this kit is the best all-around package.

Kit Contents:

- (4) GreenLite X-Struts (short or long)
- (2) GreenLite X-Strut Add-On Jacks

- (2) Ratchet Straps w/ Wire Hooks
- (2) Ratchet Straps w/ Chains
- (3) Ratchet Straps w/ Snaps
- (4) Clusters
- (4) 4' Chains w/ 8" J, Grabs, Mini-J & T-Hook
- (1) Grade 80 Chain w/ Grab Hooks
- (2) Wood/Plastic Hybrid Wedges
- (2) 20" long 1" Stakes w/ Heads
- (2) 4' long 1" Pickets w/ Collars



TEXAS 3-POINT KIT GLX-TX3P

This kit allows for stabilization and lifting of one car. Because the kit comes with a variety of accessories, it is also suitable for stabilization in complicated or multi-vehicle scenarios.

KitContents:

- (3) GreenLite X-Struts (short or long)
- (2) GreenLite X-Strut Add-On Jacks

- (1) Ratchet Straps w/ Wire Hooks
- (2) Ratchet Straps w/ Chains
- (3) Ratchet Straps w/ Snaps
- (2) Clusters
- (2) 4' Chains w/ 8" J, Grabs, Mini-J & T-Hook
- (1) Grade 80 Chain w/ Grab Hooks
- (2) Wood/Plastic Hybrid Wedges
- (1) 4' long 1" Picket w/ Collars



2-CAR DELUXE KIT GLX-2CRX

This kit is capable of stabilizing and lifting two cars in almost any situation, and can handle up to three cars in a more simple application. Accessories allow for many different applications and make stabilization in complex scenarios faster and easier.

Kit Contents:

- (6) GreenLite X-Struts (short or long)
- (3) GreenLite X-Strut Add-On Jacks

- (4) Ratchet Straps w/ Wire Hooks
- (2) Ratchet Straps w/ Chains
- (3) Ratchet Straps w/ Snaps
- (4) Clusters
- (4) 4' Chains w/ 8" J, Grabs, Mini-J & T-Hook
- (1) Grade 80 Chain w/ Grab Hooks
- (4) Wood/Plastic Hybrid Wedges
- (4) Load Spread Pads
- (4) 20" long 1" Stakes w/ Heads
- (4) 4' long 1" Pickets w/ Collars

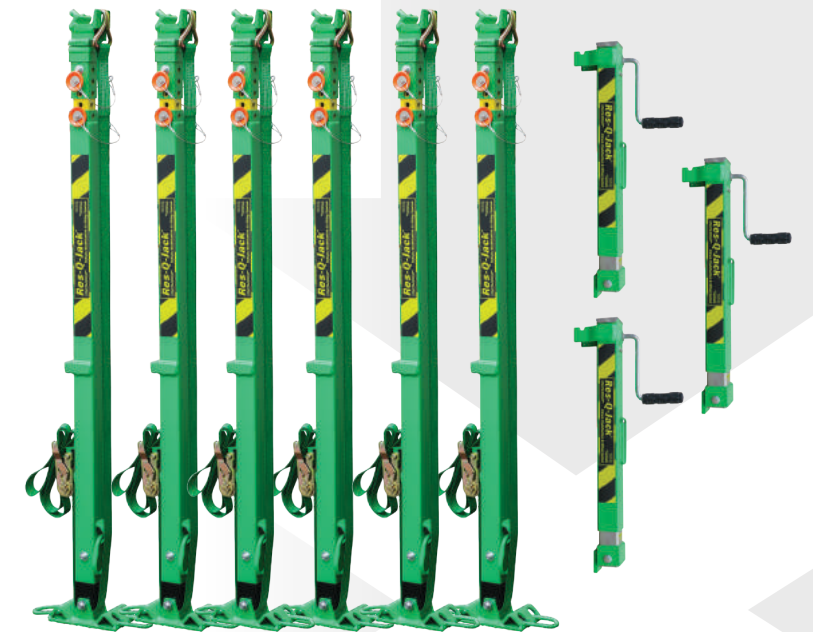



RJ3 SERIES STRUTS

The RJ3 Series is our longest standing line of stabilization and lifting struts. Each strut is made from heavy-duty steel and operates with hardened steel tab-lock pins. The RJ3 and Spacesaver Jack Stands feature integrated jacks for 4,000lbs. of built-in lifting power at a 2:1 Safety Factor!



RJ3 JACK STAND
RJ3-JKST

The RJ3 Jack Stands are the struts that started it all. This strut revolutionized the industry with its integrated jack, giving you the ability to lift while stabilizing. Featuring a modular design, the RJ3 Jack Stand is capable of being disassembled and rearranged to accommodate different applications. The RJ3 Series struts are designed to be rugged, versatile and easy to use. Operates with our easy-to-use Tab-Lock pins. Includes CAM Buckle Straps, carry handle, and Swivel CRG Head Fitting.

TECHNICAL SPECIFICATIONS

- 2:1 SAFETY FACTOR**
In-house & 3rd party tested.
- SHORING WLL: 4,000 LBS./ 1,814 KG.**
Fully extended with centered load.
- LIFTING WLL: 4,000 LBS./ 1,814 KG.**
- HEIGHT EXTENDED: 105"/267 CM.**
HEIGHT COLLAPSED: 52.5"/134 CM.
- WEIGHT TOTAL: 52 LBS./ 24 KG.**



SPACESAVER JACK STAND
SPS-JKST

The Spacesaver Jack Stand is the answer to your common storage problems! The Space Saver series maintains the same WLL and many of the same features as the standard RJ3, but has the ability to collapse to just 36.5" for easy storage. This strut features a modular design and operates with our easy-to-use Tab-Lock pins. Includes CAM Buckle Straps, carry handle, and Swivel CRG Head Fitting.

TECHNICAL SPECIFICATIONS

- 2:1 SAFETY FACTOR**
In-house & 3rd party tested.
- SHORING WLL: 4,000 LBS./ 1,814 KG.**
Fully extended with centered load.
- LIFTING WLL: 4,000 LBS./ 1,814 KG.**
- HEIGHT EXTENDED: 104"/264 CM.**
HEIGHT COLLAPSED: 36.5"/94 CM.
- WEIGHT TOTAL: 52 LBS./ 24 KG.**



RJ3 ADJUSTABLE STAND
RJ3-ADST

The RJ3 Adjustable Stand is our most simple vehicle stabilization strut, with a single pin operation. The RJ3 Adjustable Stand operates with our easy-to-use Tab-Lock pins, and includes CAM Buckle Straps, Fixed CRG Head Fitting and built-in carry handle. **Stabilization only, no lifting capability.**

TECHNICAL SPECIFICATIONS

- 2:1 SAFETY FACTOR**
In-house & 3rd party tested.
- SHORING WLL: 4,000 LBS./ 1,814 KG.**
Fully extended with centered load.
- LIFTING WLL: NONE**
- HEIGHT EXTENDED: 85"/216 CM.**
HEIGHT COLLAPSED: 56"/142 CM.
- WEIGHT TOTAL: 37 LBS./ 17 KG.**



SPACESAVER ADJUSTABLE STAND
SPS-ADST

The Spacesaver Adjustable Stand features the same collapsible design as the Jack Stand, but is built strictly for vehicle stabilization. This strut features a modular design and operates with our easy-to-use Tab-Lock pins. Includes CAM Buckle Straps, carry handle, and Swivel CRG Head Fitting. **Stabilization only, no lifting capability.**

TECHNICAL SPECIFICATIONS

- 2:1 SAFETY FACTOR**
In-house & 3rd party tested.
- SHORING WLL: 4,000 LBS./ 1,814 KG.**
Fully extended with centered load.
- LIFTING WLL: NONE**
- HEIGHT EXTENDED: 103.5"/271 CM.**
HEIGHT COLLAPSED: 36.5"/93 CM.
- WEIGHT TOTAL: 43 LBS./ 20 KG.**

RJ3 SERIES STRUTS

COMPLETE KITS

1. CHOOSE YOUR KIT

We've designed our kits through years of experience and feedback to give you options to fit your needs and your budget.

2. CHOOSE YOUR STRUTS

Choose any combination of short or long strut. When choosing sizes, we recommend an equal number of short and long struts when possible.

3. GET YOUR FREE TRAINING*

All of our kits come with intensive in-service training at your facility, at no cost to you!* Your authorized dealer will provide you and your crew basic training on your new tools until you are comfortable using them.

*Valid within the continental US only. Dealer may add a travel charge for instances of excessive travel.



2-POINT STANDARD KIT
RJ3-2KIT (RJ3 Series)
SPS-2KIT (Spacesaver)

This kit gives you the ability to perform the four basic techniques found in our Quick Reference Guide, including: Wheel-Resting Side Lift, Wheel-Resting Rear Lift, Side-Resting Front Lift, and Roof-Resting Rear Lift.

- Kit Contents:**
(2) Jack Stand Struts

- (1) Ratchet Straps w/ Wire Hooks
- (2) Ratchet Straps w/ Snaps
- (2) Clusters
- (2) 4' Chains w/ 8" J, Grabs, Mini-J & T-Hook
- (1) Grade 80 Chain w/ Grab Hooks



4-POINT DELUXE KIT
RJ3-4PTX (RJ3 Series)
SPS-4PTX (Spacesaver)

This kit gives you the ability to stabilize two cars and lift one of them. With enough accessories to manage and control all directions of movement, this kit is the best all-around package.

- Kit Contents:**
(2) Jack Stand Struts
(2) Adjustable Stands

(2) Ratchet Straps w/ Wire Hooks
(2) Ratchet Straps w/ Chains
(3) Ratchet Straps w/ Snaps
(4) Clusters
(4) 4' Chains w/ 8" J, Grabs, Mini-J & T-Hook
(1) Grade 80 Chain w/ Grab Hooks
(2) Wood/Plastic Hybrid Wedges
(2) 20" long 1" Stakes w/ Heads
(2) 4' long 1" Pickets w/ Collars

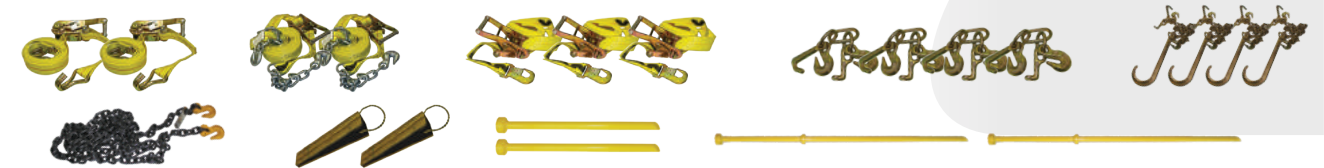

TEXAS 3-POINT KIT
RJ3-TX3P (RJ3 Series)
SPS-TX3P (Spacesaver)

This kit allows for stabilization and lifting of one car. Because the kit comes with a variety of accessories, it is also suitable for stabilization in complicated or multi-vehicle scenarios.

- KitContents:**
(2) Jack Stand Struts
(1) Adjustable Stand

- (1) Ratchet Straps w/ Wire Hooks
- (2) Ratchet Straps w/ Chains
- (3) Ratchet Straps w/ Snaps
- (2) Clusters
- (2) 4' Chains w/ 8" J, Grabs, Mini-J & T-Hook
- (1) Grade 80 Chain w/ Grab Hooks
- (2) Wood/Plastic Hybrid Wedges
- (1) 4' long 1" Picket w/ Collars



2-CAR DELUXE KIT
RJ3-2CRX (RJ3 Series)
SPS-2CRX (Spacesaver)

This kit is capable of stabilizing and lifting two cars in almost any situation, and can handle up to three cars in a more simple application. Accessories allow for many different applications and make stabilization in complex scenarios faster and easier.

- Kit Contents:**
(3) Jack Stand Struts
(3) Adjustable Stands

(4) Ratchet Straps w/ Wire Hooks
(2) Ratchet Straps w/ Chains
(3) Ratchet Straps w/ Snaps
(4) Clusters
(4) 4' Chains w/ 8" J, Grabs, Mini-J & T-Hook
(1) Grade 80 Chain w/ Grab Hooks
(2) Wood/Plastic Hybrid Wedges
(4) Load Spread Pads
(4) 20" long 1" Stakes w/ Heads
(4) 4' long 1" Pickets w/ Collars

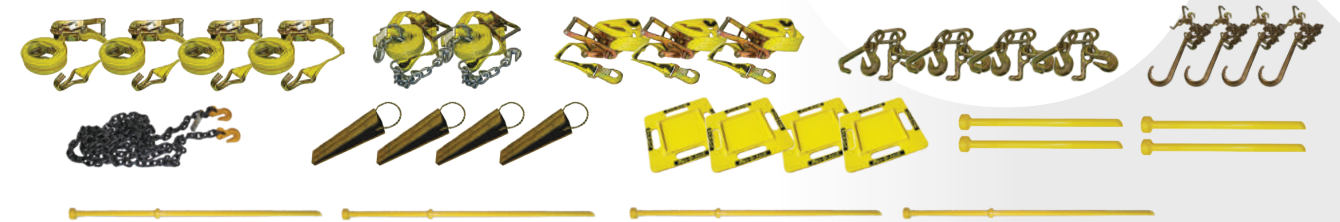



PIN-FREE EXTENSION TUBING

SPX-12EX (12’/31 CM) | SPX-24EX (24’/61 CM) | SPX-36EX (36’/92 CM)
 Reach new heights with these extension tubes. These easy-to-use extensions are machined from 6061 T-6 aluminum and provide extra length to your Pin-Free X-Struts, Trench Shore, and Technical Rescue Kits. Available in one, two and three foot lengths.



LARGE BASE PLATE
 SPX-12BP
 This 12’/31cm. swiveling base plate will work in a wide range of scenarios, especially when you need to spread out the load on soft ground. Includes attachment for straps. Made from machined aluminum.



SMALL EXTRICATION BASE PLATE
 SPX-EXBP
 Our standard, swiveling base plate, but built specifically for the Super X. This lightweight design includes D-rings for stakes or for engaging straps and chains. Features machined aluminum attachment with powder coated steel base and rings.



SWIVEL CRG HEAD
 SPX-SCRG
 The CRG combines the Channel, Round Point and Chain Grab end fittings into one revolutionary head, making changing heads during a rescue unnecessary. Fits Super X, Apex & Auto X.



SUPER X TRIPOD HEAD
 SPX-TRPD
 Turn three Super X-Struts into a technical rescue tripod with this pin-free head fitting. (pictured left) The Tripod Head features a powder coated steel crown with three machined aluminum attachments for fast setup. Struts sold separately.



TRENCH PLATE
 SPX-TRBP
 This swiveling ball-joint plate is ideal for trench rescue shoring, with 4 corner holes for securing with nails or screws. Made from machined aluminum.



FLAT PLATE HEAD
 SPX-FLTH
 This 6’/15cm. fixed plate is your straightforward shoring head. Recommended for structural applications with the Super X, but also compatible with the SPX Trench Shore. Made from machined aluminum.

NEW DARLINGTON HEAD | DAR-HEAD

The Darlington Head allows you to marry two struts together by linking the CRG Heads together. This allows for an easier set up to perform the Darlington Roll. Also can be used to set up a Bi Pod using two struts. **Compatible with ALL Res-Q-Jack Struts.**

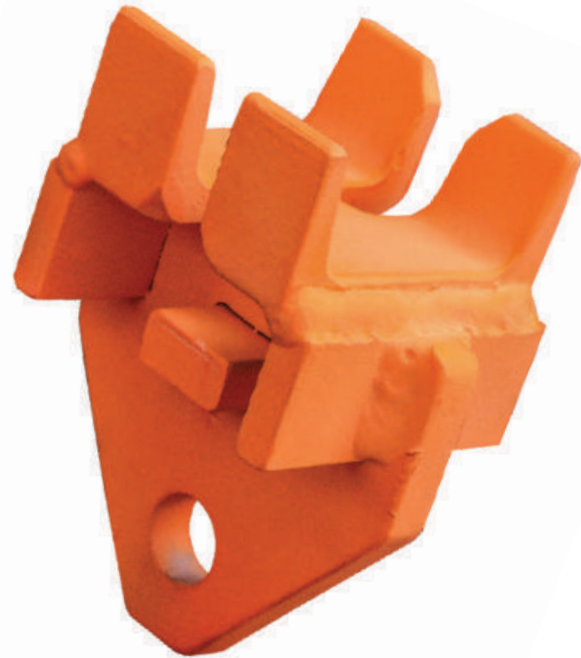

TRIPOD HEAD
ALX-TRPD | RJ3-TRPD | GLX-TRPD
Turn your pin-operated struts into a tripod for technical rescue scenarios. Features powder coated steel crown and tubular steel legs. Secured with our hardened steel tab lock pins. Steel X / RJ3 and GreenLite heads include 36"/92cm. extensions to reach up to 9'/2.75m.



SWIVEL CRG HEAD
ALX-SCRG | STX-SCRG | RJ3-SCRG | GLX-SCRG
The CRG combines the Channel, Round Point and Chain Grab end fittings into one revolutionary head, and makes changing heads during a rescue unnecessary. The swivel CRG tip swivels 360° to easily find purchase points at any angle.



FIXED CRG HEAD
RJ3-FCRG
The same basic design and functionality as our Swivel CRG Head, but without the ability to swivel. Currently only available as a replacement for the RJ3 Jack Stand.



SQUARE HEAD
ALX-SQUR | RJ3-SQUR
This end fitting is equipped with a square plate for use in structural situations like light shoring against a flat overhead surface. Available for Aluminum X, Steel X & RJ3 Series.

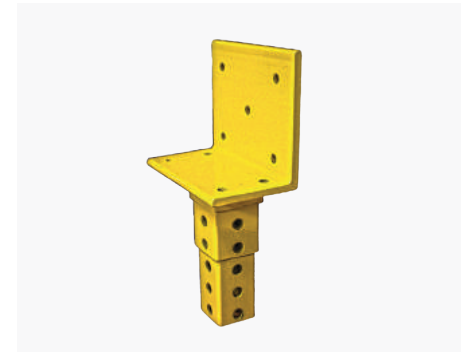

L-PLATE
ALX-LPLT | RJ3-LPLT
This end fitting is designed for beam support during lightweight structural shoring. Its L-shaped design cradles the beam, and includes holes on each side for securing with nails or screws. Available for Aluminum X, Steel X & RJ3 Series.



C-HEAD
ALX-CHED | RJ3-CHED
This end fitting allows for a cradle of wide members, such as an A-post, with an assuredly positive hold. Available for Aluminum X, Steel X & RJ3 Series.



RJ3 BASE
RJ3-BASE
Our standard base plate for the RJ3 Series. D-Ring links are permanently attached for easy connection of base restraints, as well as CAM buckle straps for convenience. *Compatible with RJ3 only.*



FIXED BASE
RJ3-FBAS
This rigid base stands straight up, and is useful for many applications, such as a jack unit serving as a low level object lifting device, for roll-overs or confined space applications. *Compatible with RJ3 only.*



RJ3 STRUCTURAL PACKAGE
PKG-STRL
The Structural accessory package includes the end fittings made for structural rescues, and the fixed base which is designed specifically for structural applications. *Compatible with RJ3 only.*

EZ PICKET PLATE | ACC-EAPP

The EZ Picket Plate features three oversized collars for 1" diameter pickets, which are set at 20° angles for fast and precise placement. Includes two extra holes to accommodate pickets up to 1 5/8" diameter. The EZ Picket Plate measures 30"/76cm. long by 6"/15cm. wide and features a built-in carry handle, D-Ring and diamond plate foot print.

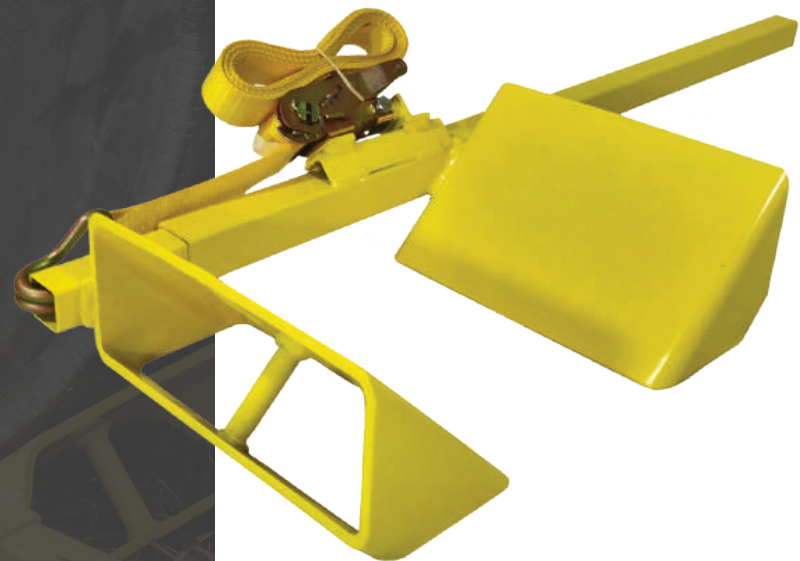
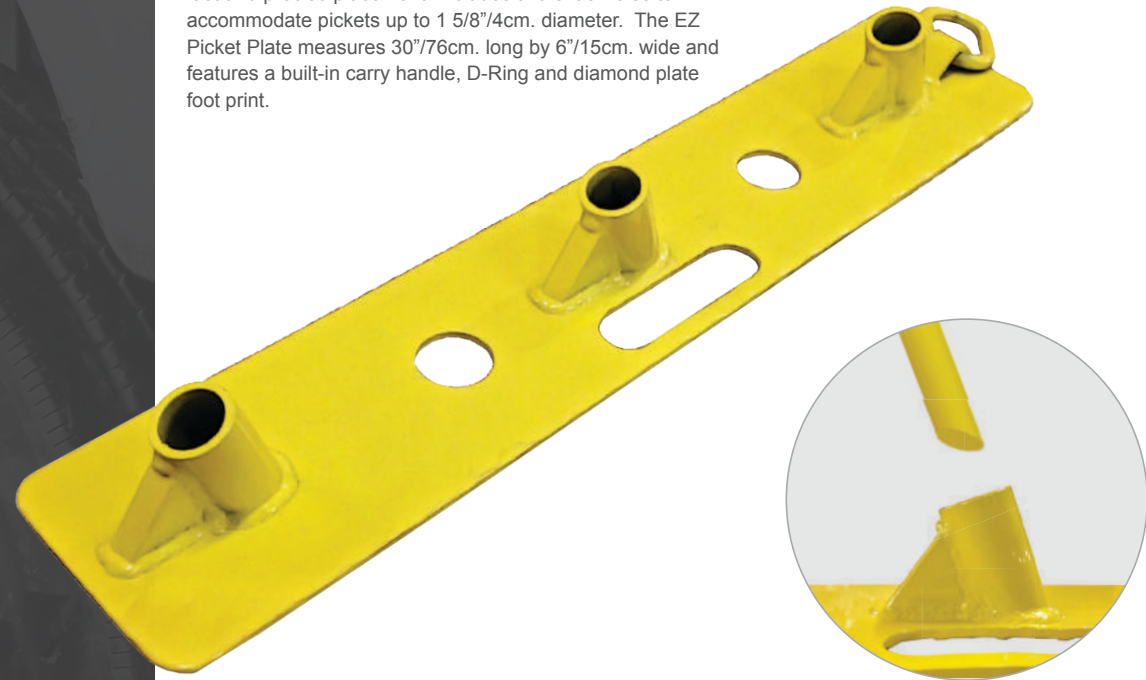

RATCHETING WHEEL CHOCK | ACC-WCHK

A rugged and easy-to-use option for chocking wheels, this chock won't "push" both sides of the wheel with just one piece of equipment, as do oversized blocks and chocks.



STAKE
ACC-STKE

Our Stake is 20"/51cm. long and features a solid core with a 45° tip. Measures 1 1/2". in diameter and weighs 5lbs./2kg.

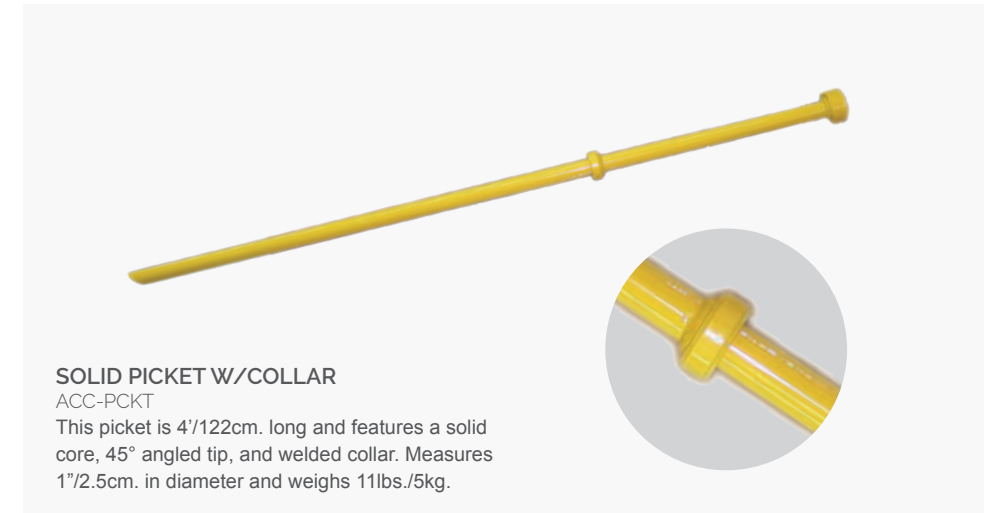

SOLID PICKET W/COLLAR
ACC-PCKT

This picket is 4'/122cm. long and features a solid core, 45° angled tip, and welded collar. Measures 1 1/2". in diameter and weighs 11lbs./5kg.



RAM PLATE
ACC-RAMP

This heavy duty, multi-purpose ram support plate should be placed over a rocker panel to achieve multiple engagement points for your ram when performing a dash displacement.



LOAD PAD
ACC-LOAD

This 14"/36cm. x 14"/36cm. load pad allows you to spread the load evenly over soft ground. Four carry holes double as stake holes, and the inner strut pocket is designed to fit the strut base.



CONE PIN
ACC-SCNP (STX/GLX)
ACC-ACNP (Aluminum)

Shipped with our X-Strut® Series, these ergonomic pins are easy to operate and fast to use. Steel X pins and Green Lite™ pins are 3/8"/1cm. in diameter (4,000lbs./1,818kg. WLL), and Aluminum X pins are 3/4"/2cm. in diameter (10,000lbs./4,545kg. WLL).



TAB LOCK PIN
ACC-TABO

Our standard, easy-to-use, 3/8"/1cm. diameter pins. With a self-contained method of retaining the pin, our tab lock pins eliminates cotter pins or other accessories that would require removal of gloves (4,000lbs./1,818kg. WLL).



EXTENSION TUBING
ACC-EXTT

We offer custom sizes of extension tubing to maximize adjustability of stands. Available in either 2"/5cm. or 2 1/4"/6cm. sizes. Sold per inch of tubing.



CLOSE QUARTERS RATCHET STRAP
ACC-CQRS
This 15'4.5m. strap is 2"/5cm. wide with a WLL of 3,300lbs./1,500kg. It includes a ratchet with a single wire hook attached to the ratchet by the bolt. This eliminates the need for extra webbing and shortens the ratchet by 6"/15cm.



HYBRID WEDGE
ACC-WDGE
This wedge is made with plastic sandwiched between two pressure treated wood skins, reducing slippage associated with all-plastic cribbing.



T-HOOK
ACC-THKL
These hooks are designed to fit most car frame slots and come with links for easy application. Hooks are grade 70 and rated for 4,700 lbs./2,136kg.



CLUSTER
ACC-CLST
This cluster of hooks contains one T-Hook, one mini-J and 2 grab hooks. With two connecting links for rapid attachment, this grade 70 cluster is convenient for any scenario.



RATCHET STRAP W/ SNAP HOOKS
ACC-RSSN
This 2"/5cm. x 15'4.5m. medium duty ratchet strap has a WLL of 2,000lbs./909kg., and the snap hooks at each end can hook inside items such as a link of 3/8"/1cm. chain.



CAM BUCKLE STRAP
ACC-CAMB
Attached to a bolt plate for easy connection to a base, this strap is 2"x9'/2.75m. with a 700lbs./318kg. WLL and an S-hook at its end.



J-HOOKS
ACC-JHK8 | 8"/20 cm.
ACC-JH15 | 15"/38 cm.
These large hooks can attach to a wide variety of structures including posts, axles, or frame components. The hooks are grade 70, rated for 4,700lbs./2,136kg., and come in two useful sizes.



CHAIN & HOOK SLING ASSEMBLY
ACC-SLG8 | 8"/20 cm.
ACC-SL15 | 15"/38 cm.
Designed specifically for vehicle stabilization, these J-Hooks are attached to a grab hook and 4' of 5/16" grade 70 chain connected to another grab hook, a mini-J and a T-Hook.

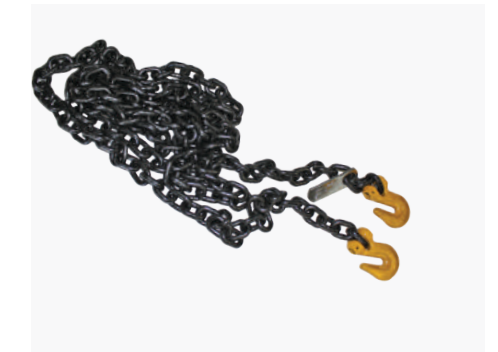

GRADE 80 CHAIN
ACC-CHAN | 16'
ACC-CHAN-20 | 20'
This rugged chain is 3/8"/1 cm with grab hooks and a WLL of 7,100 lbs/3,227 kg, this chain is approved for overhead lifting. Available in 16'/5 m or 20'/6 m lengths.



RATCHET STRAP W/ CHAIN
ACC-RSCH
This 27'/8m. strap is 2"/5cm. wide with a 3,300lbs./1,500kg. WLL. Its attached D-Ring, 3/8"/1cm. chain, and grab hook provide a strong base restraint.



RATCHET STRAP W/ WIRE HOOKS
ACC-RSWH
This 15'4.5m. strap is 2"/5cm. wide with a 3,300lbs./1,500kg. WLL. It includes ratchet and attached wire hooks which are compatible with our base plates.

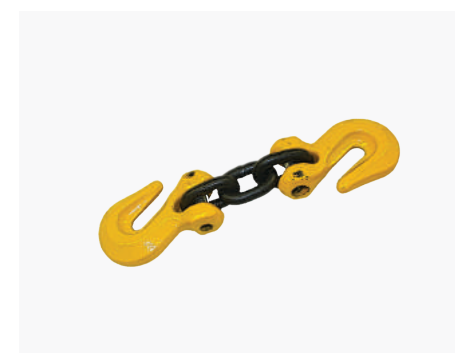

CHAIN SHORTENER
ACC-CHSH
The chain shortener consists of two 3/8"/1cm. grade 80 grab hooks connected by two 3/8"/1cm. grade 80 chain links, allowing you to shorten a chain by making a loop anywhere in the chain.



RATCHET BINDER | ACC-RTCH
Great for tightening chain in many different stabilization situations, the ratchet binder is fast, convenient and easy to use.

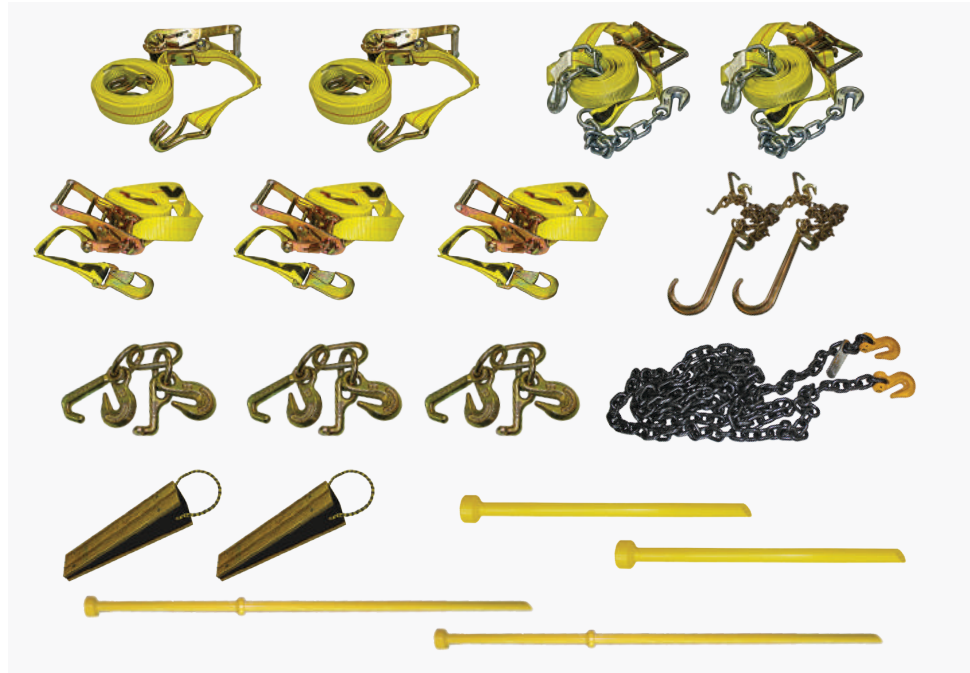

ALL PURPOSE PACKAGE
PKG-ALLP

Get the most out of your strut purchase. With the All-Purpose Accessory Package, you will be prepared for a wide variety of rescues.

- Includes:**
- (2) Ratchet Straps w/ Wire Hooks
 - (2) Ratchet Straps w/ Chains
 - (3) Ratchet Straps w/ Snaps
 - (2) Chain & Hook Assemblies (8"/20cm.)
 - (3) Clusters
 - (1) Grade 80 Chain w/ Grab Hooks (16'/5m.)
 - (2) Wood/Plastic Hybrid Wedges
 - (2) 20"/51cm. x 1 1/2". Stakes w/ Heads
 - (2) 4'/122cm. x 1 1/2". Pickets w/ Collars

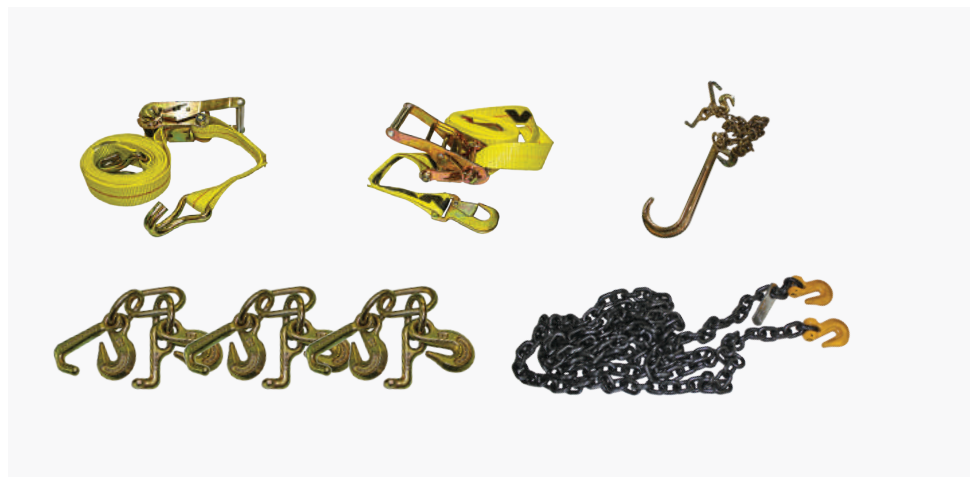

BASIC PACKAGE
PKG-BASC

This basic package includes the accessories needed for our most basic vehicle set-ups.

- Includes:**
- (1) Ratchet Straps w/ Wire Hooks
 - (1) Ratchet Straps w/ Snaps
 - (1) Chain & Hook Assembly (8"/20cm.)
 - (3) Clusters
 - (1) Grade 80 Chain w/ Grab Hooks (16'/5m.)



RES-Q-SAW
HEAVY-DUTY CUTTING SAW

Gaining access to a car in an MVA can take long, precious moments. With the Res-Q-Saw, you can significantly reduce access time, saving those critical moments.

The Res-Q-Saw is capable of cutting steel, aluminum and stainless steel without heat, burrs or coolant. The powerful motor is double-insulated and Earth-grounded, and can cope with the heaviest of work. The Res-Q-Saw is perfect to aid in vehicle stabilization and extrication. With a long-life blade that will cut up to 260 feet of 1/4" steel plate, the Res-Q-Saw's high-quality construction comes with a full one-year warranty.

The Res-Q-Saw package includes heavy-duty carrying case, safety goggles and earplugs.

- SPECIFICATIONS:**
- Weight: 19.75 lbs./9 kg.
 - Arbor: 260'/79 m., .25"/.6 cm.
 - Amps: 15 W • Watts: 1750 • Volts: 110 • RPMs: 2700

- RQS-5BLD Saw w/ 5 Steel Blades
- RQS-1BLD Saw w/ 1 Steel Blade
- RQS-SMBL One Steel / Metal Blade
- RQS-SABL One Soft Aluminum Blade
- RQS-ALBL One Aluminum Blade
- RQS-SSBL One Stainless Blade
- RQS-WSBL One Wood Saw Blade



*Kit pictured with five steel blades

GET YOUR FREE HANDS-ON DEMO

TRAINING NIGHT, DRILL NIGHT,
ONE-ON-ONE AT YOUR FACILITY

All you need is a junk vehicle and we'll do the rest! Get hands-on with our tools in the comfort of your own facility and experience the Res-Q-Jack difference with a FREE Demo. Just give us a call and we'll put you in touch with your local Res-Q-Jack dealer to come to your facility, at your convenience, to show you and your department the capabilities and advantages of our tools.



Res-Q-Jack, Inc. • 1580 Lake Street • Elmira, NY 14901
(607)739-1209 • (607)739-4583 (fax) • info@res-q-jack.com

